

DR SERIES FORCED DRAFT  
WATER BOILER (DR350-DR850) REVERSE CONSTRUCTION

EFFECTIVE DATE: 5/30/08  
REPLACES: 12/9/03

NOTES:

1. ALL DIMENSIONS ARE IN INCHES THOSE IN PARENTHESES ARE CENTIMETERS.
2. LOCATION DIMENSIONS ARE ALL  $\pm 1/2"$ .
3. GAS TRAIN, CONTROL AND BURNER CONFIGURATION WILL VARY DEPENDING ON JOB SPECIFICATIONS & CONDITIONS.
4. DIMENSIONS ARE SUBJECT TO CHANGE WITHOUT NOTICE. CONSULT FACTORY FOR CERTIFIED DIMENSIONS.
5. ALL FLANGES ARE 150# UNLESS OTHERWISE NOTED, FLANGES TO STRADDLE CENTER LINE.

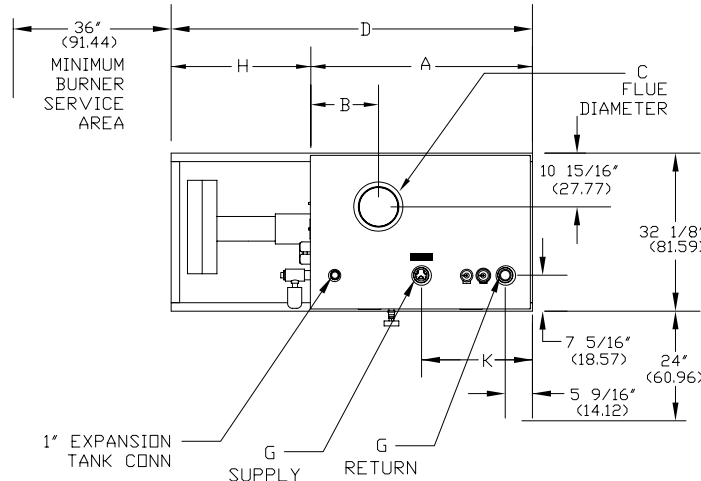

MINIMUM  
TUBE  
REMOVAL  
CLEARANCE

PLAN VIEW

MODEL	K
350-450	17"
650-850	22 9/16"

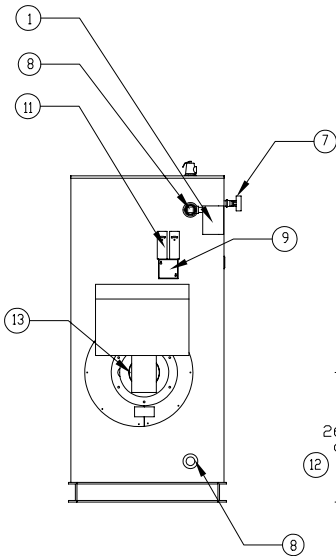

FRONT VIEW

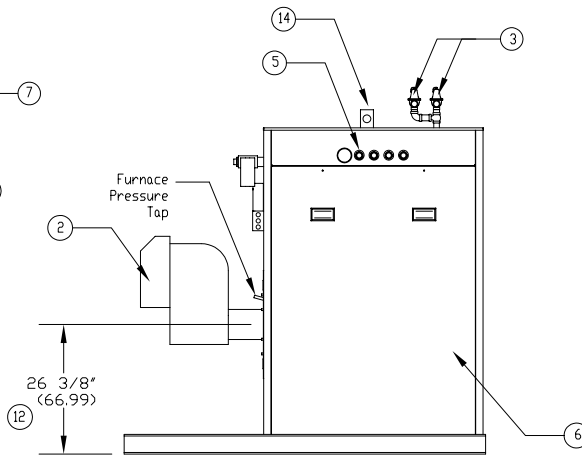

RIGHT SIDE VIEW

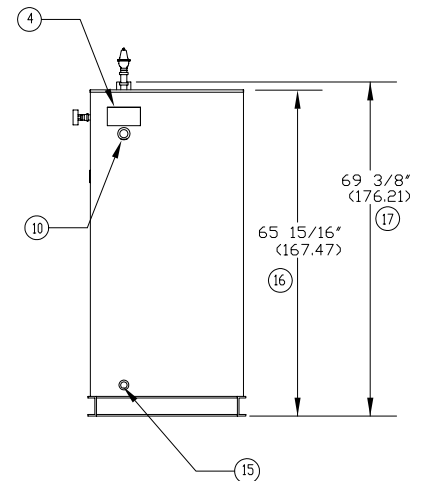

REAR VIEW

1. PROBE TYPE L.W.C.D.-
2. FORCED DRAFT BURNER
3. RELIEF VALVE
4. ASME NAMEPLATE
5. CONTROL CONNECTION

6. JACKET ACCESS PANELS
7. PRESS./TEMP. GAUGE
8. CLNDOUT./INSP. OPNG.-1 1/2"NPT
9. ELEC. ENCLOSURE-
10. AUX. CONNECTION 1 1/4" NPT

11. AQUASTATS
12. BURNER CENTER LINE
13. OIL PUMP LOCATION
14. LIFTING LUG
15. DRAIN CONNECTION

16. HEIGHT OVER JACKET
17. HEIGHT OVER SUPPLY

BOILER MODEL	DR350	DR450	DR650	DR850
A-LENGTH OVER JACKET	33 3/4" (84.77)	33 3/4" (84.77)	45 1/16" (114.45)	45 1/16" (114.45)
B-FLUE LOCATION	13 3/4" (34.92)	13 3/4" (34.92)	13 1/8" (33.33)	13 1/8" (33.33)
C-FLUE DIAMETER	6" (15.24)	6" (15.24)	8" (20.32)	8" (20.32)
D-LENGTH OVER BASE	62 1/8" (157.79)	62 1/8" (157.79)	73 1/2" (186.69)	73 1/2" (186.69)
G-SUPPLY / RETURN NOZZLE SIZE	2" (5.08)	2" (5.08)	2" (5.08)	2" (5.08)
H-BURNER EXTENSION	CONSULT FACTORY FOR BURNER EXTENSION APPLICATIONS			



BRYAN STEAM LLC

783 NORTH CHILI AVE  
PERU, INDIANA 46970

ORDER NO.:  
ORDER REV. NO.:  
FORM NO.: 2177

# DR SERIES FORCED DRAFT WATER BOILERS REVERSE CONSTRUCTION

BOILER MODEL		DR350	DR450	DR650	DR850
INPUT	MBH	350	450	650	850
	(KW)	102.5	131.8	190.4	249.0
OUTPUT*	MBH	292.3	375.8	542.8	709.8
	(KW)	85.6	110.1	159.0	208.0
BOILER HORSEPOWER*	HP	9	11	16	21
	(KW)	86	110	159	208
TUBE DIAMETER	INCHES	1.00	1.00	1.00	1.00
	(CM)	2.54	2.54	2.54	2.54
NUMBER OF TUBES		18	18	29	29
PRESSURE VESSEL					
VOLUME	GAL	20	20	30	30
	(L)	75.7	75.7	113.6	113.6
HEATING SURFACE	SQ FT	66	66	103	103
	(SQ M)	6.1	6.1	9.6	9.6
OPERATING WEIGHT	LBS	1,320	1,320	1,900	1,900
	(KG)	598.8	598.8	861.8	861.8
SHIPPING WEIGHT	LBS	1,150	1,150	1,650	1,650
	(KG)	521.6	521.6	748.4	748.4

\* Output and Boiler HP based on an average natural gas combustion efficiency.