

BE Series Electric Boiler 15# Steam Design 30 kw to 390 kw

EFFECTIVE DATE: 2-22-22
REPLACED DATE: 3-1-04

- NOTES:
1. DIMENSIONS ARE SUBJECT TO CHANGE WITHOUT NOTICE. CONSULT FACTORY FOR CERTIFIED DIMENSIONS.
2. TIE IN OF EXPANSION TANK CONNECTION IS ESSENTIAL TO INSURE PROPER OPERATION OF THE LOW WATER CUT-OFF FLOAT
3. NOT INTENDED FOR USE AS A PRINCIPAL HEATING SOURCE FOR LIVING SPACE OF AN INDIVIDUAL RESIDENCE

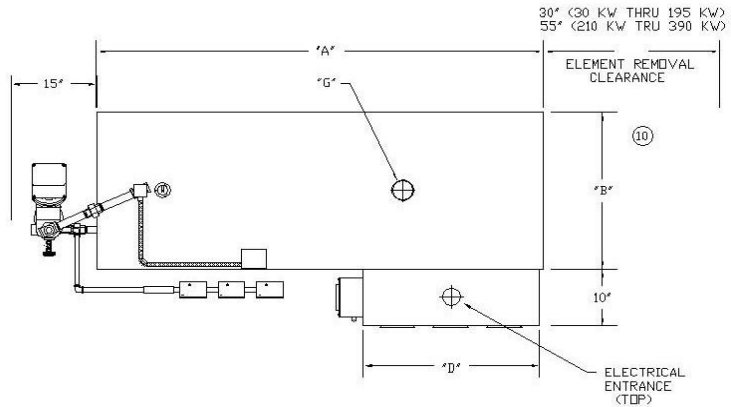

TOP VIEW

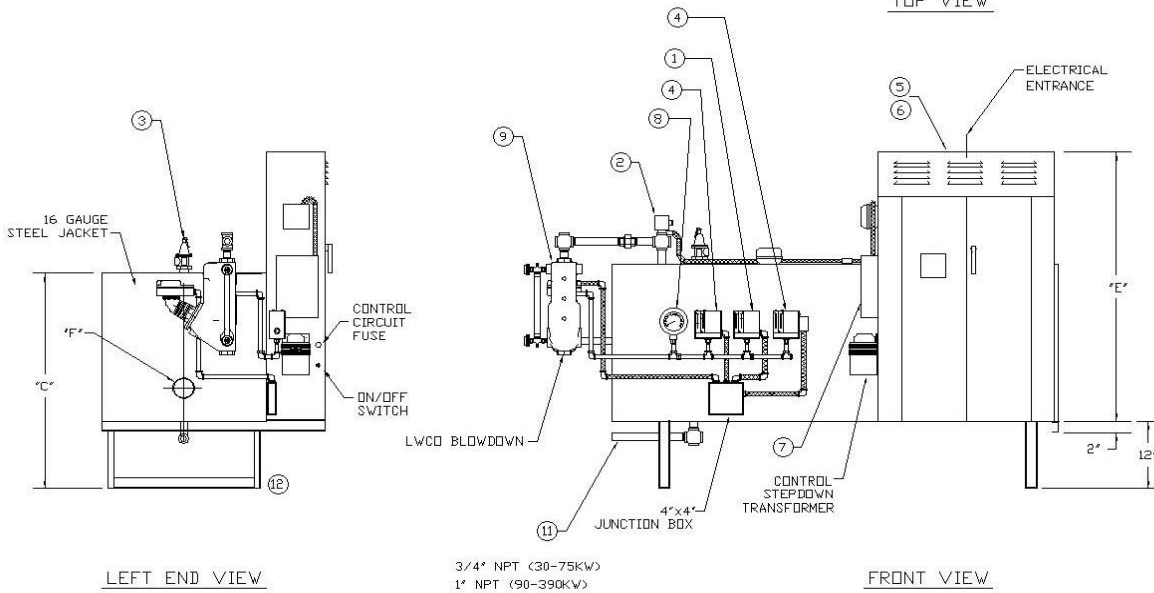

LEFT END VIEW

3/4" NPT (30-75kW)
1" NPT (90-390kW)

FRONT VIEW

- | | | |
|--|---|--|
| 1. OPERATOR
2. PROBE TYPE LWCO
3. RELIEF VALVE
4. PRESSURE RETROL | 5. POWER PANEL
6. CONTROL PANEL
7. STEP CONTROLLER
8. PRESSURE GAUGE | 9. LWCO/PUMP CONTROLLER
10. ELEMENT ACCESS
11. BOTTOM BLOW DOWN
12. STRUCTURAL STEEL LEGS |
|--|---|--|

KW	BES Series								Fluid Cap. Oper. Level Gallons		Aprox. Ship WT.
	Vessel Dimensions			Power Panel Voltage		Inlet	Outlet	Water	Steam		
	length	width	height	208-230/3/60						380-460-575/3/60	
30	48	20	32	20	30	2	2	24	13	775	
45	48	20	32	20	30	2	2	24	13	775	
60	48	20	32	30	36	2	2	24	13	775	
75	48	20	32	30	36	2	2	24	13	850	
90	48	28	40	30	36	3	3	52	32	1000	
105	48	28	40	30	48	3	3	52	32	1025	
120	48	28	40	30	48	3	3	52	32	1050	
135	48	28	40	30	48	3	3	52	32	1300	
150	48	28	40	30	48	3	3	52	32	1325	
165	48	28	40	30	48	3	3	52	32	1350	
180	48	28	40	30	48	3	3	52	32	1400	
195	48	28	40	30	66	3	3	52	32	1450	
210	76	28	40	C/F	C/F	3	3	105	69	1950	
240	76	28	40	C/F	C/F	3	3	105	69	2000	
270	76	28	40	C/F	C/F	3	3	105	69	2450	
300	76	28	40	C/F	C/F	3	3	105	69	2500	
330	76	28	40	C/F	C/F	3	3	105	69	2550	
360	76	28	40	C/F	C/F	3	3	105	69	2600	
390	76	28	40	C/F	C/F	3	3	105	69	2650	



BRYAN BOILERS LLC

783 NORTH CHILI AVE
PERU, INDIANA 46970

FORM NO.:

2246